

□ Function & Features

- One or Two analog inputs
- Converting a DC input into two isolated process signals
- Multiple functions
- Received two DC inputs and provides outputs proportional to the calculation functions of the inputs
- FUNCTIONS (addition, subtraction, multiplication, division, etc.)
- Four-way isolation (input/output1/output2/power)
- Protection Input and output TVS diode
- Analog One or Two outputs (independent output module)
- Universal power input
- Power fuse (240V/0.12A)



□ GENERAL SPECIFICATIONS

- Housing Material : polyamide UL94.V0 Grey
- Rated wire size : 0.3~2.5mm² / 22~14 AWG
- Isolation : Input to Output to Power
- Easy Calibration of the Gain (Max. ±15% of F.S) and Offset(Max. ±15% of F.S)
- Power Supply : DC 18~32V or AC 85~265V
- Operating Temperature : -5~55 °C (storage : -20~70 °C)
- Operating Humidity : 90% RH max. (Non-condensing)
- Mounting : Rail Mounting
- Dimension : 22.5(W) X 75(H) X 107(D) (Unit : mm)
- Weight : about 140g

SCHEMATIC CIRCUIT & CONNECTION DIAGRAM

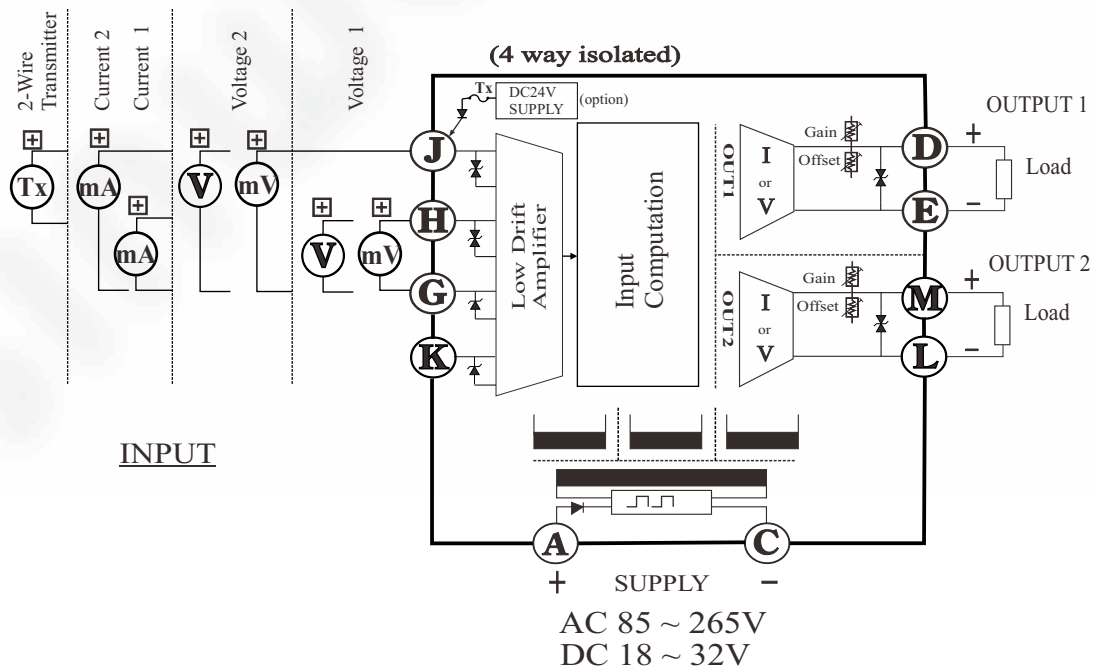

□ Input & Output

■ INPUT (A & B) :

● CURRENT

- Programmable range : -20 mA ~ +20 mA DC
- Measurement range : ±21 mA Max.
- Input resistance : 50Ω(0.5W)

● LOOP POWERED CURRENT

- Supply Voltage : 18 ~25 V DC(Terminal) / 4~20 mA

● VOLTAGE :

- Programmable Range : -10V ~ +10V DC
- Measurement range : ±11V DC
- Input resistance Normal : 1 MΩ

■ ANALOG OUTPUT :

- DC Current : 0(4)~20 mA DC max. (Load resistance : 600Ω max.)
- DC Voltage : -10V min. ~ +10V DC max. (Load Resistance : 10 KΩ or more)
- 2-Wire Transmitter(4~20 mA DC), supply out voltage (9 V ~ 35 V DC)

■ FUNCTIONS

- Analog Calculations

- [000] Normal input (A)
- [001] Square Root (A)
- [002] Root Extraction (A)
- [007] ADDER(A+B) : Addition of 2 analog inputs
- [008] SUBTRACTOR(A-B) : Subtraction of 2 analog inputs
- [009] MULTIPLIER(A*B) : Multiplication of 2 analog inputs
- [010] DIVIDER(A/B) : Division of 2 analog inputs
- [101] Normal input (B)
- [102] Square Root (B)
- [103] Root Extraction (B)
- [108] SUBTRACTOR(B-A) : Subtraction of 2 analog inputs
- [109] DIVIDER(B/A) : Division of 2 analog inputs

- Two Converters

- [201] There are two converters in the product (Only DC input (A and B))
[Input-A to Output-1, and Input-B to Output-2]

MODEL & SUFFIX CODE

SL-NDSC-

Input Type Selection (Available for Input A & Input B)

- 0 : None
- A : ± 20 mA DC (Impedance : $50 \Omega / 0.5 W$) [DC 0~1mA, 0~20mA, 4~20mA]
- B : 2-Wire Transmitter(4~20mA DC, Impedance : $50 \Omega / 0.5 W$) [supply out voltage (18 V ~ 25 V DC)]
- C : ± 10 V DC (Impedance : $1 M\Omega$ min.) [DC 0~10V, -10~+10V]
- D : ± 5 V DC (Impedance : $1 M\Omega$ min.) [DC 0~5V, 1~5V, -5~+5V]
- E : ± 1 V DC (Impedance : $1 M\Omega$ min.) [DC 0~100mV, 0~1V, -1~+1V]
- F : ± 100 mV DC (Impedance : $10 K\Omega$ min.) [DC 0~10mV, 0~50mV, 0~100mV, -100~+100mV]

R : Other Special Spec.

Output Type & Range Selection (Available for Output 1 & Output 2)

- 0 : Not Used
- 1 : DC 4~20mA (Load Resistance : 0~600 Ω)
- 2 : DC 0~20mA (Load Resistance : 0~600 Ω)
- 3 : DC 1~5V (Load Resistance : 5 K Ω or more)
- 4 : DC 0~5V (Load Resistance : 5 K Ω or more)
- 5 : DC 2~10V (Load Resistance : 10 K Ω or more)
- 6 : DC 0~10V (Load Resistance : 10 K Ω or more)
- 7 : DC -5~+5V (Load Resistance : 10 K Ω or more)
- 8 : DC -10~+10V (Load Resistance : 10 K Ω or more)
- 9 : 2-Wire Transmitter(4~20mA DC) (9V ~ 35V DC)

R : Other Special Spec.

Power Supply

- Z : AC 85~265V
- Y : DC 18~32V
- R : Other Special Spec.

Function

- 0 : Normal(Input-A) [Input-A to Output-1,2]
- 1 : Square root(A)
- 2 : Square Root Extractor(A)
- 3 : Adder (A + B)
- 4 : Subtractor (A - B)
- 5 : Multiplier (A * B)
- 6 : Divider (A / B)
- 7 : Normal(Input-B) [Input-B to Output-1,2]
- 8 : Normal(Input-A and B) [Input-A to Output-1] and [Input-B to Output-2]

R : Specify function

DIMENSION & MOUNTING METHOD

* : Max. height of components

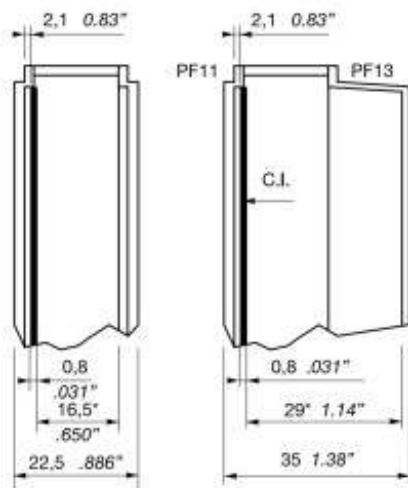

on rail EN 50035
35 x 7,5

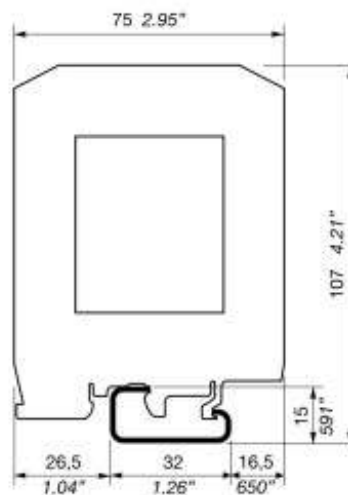

on rail EN 50022

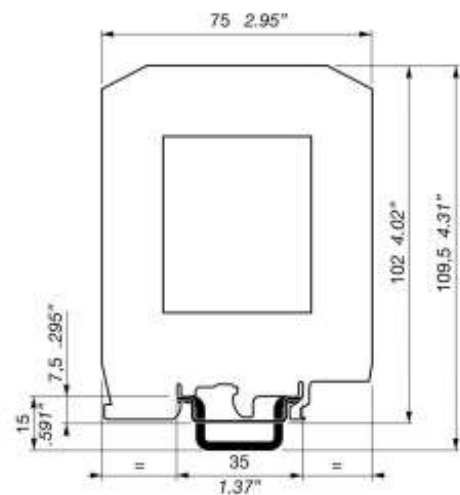

quick-connect tab
terminal dimensions

horizontal assembly

A

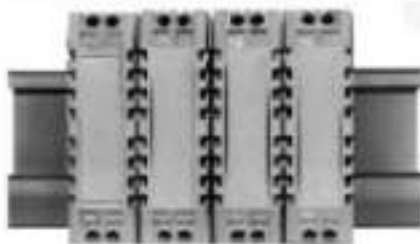

vertical assembly

B

