

□ Function & Features

- One or Two analog inputs
- Converting a DC input into two isolated process signals
- Multiple functions
- Received two DC inputs and provides outputs proportional to the calculation functions of the inputs
- FUNCTIONS (addition, subtraction, multiplication, division, etc.)
- Front-programmable 4-digit LED display
- Four-way isolation (input/output 1/output2/power)
- Protection Input and output TVS diode
- Analog One or Two outputs (independent output module)
- Universal power input
- Power fuse (240V/0.12A)



□ INSTALLATION

- Power supply : AC 85 ~ 265V or DC 18 ~ 32V (about 3VA)
- Operating temperature : -5 ~ 55 °C (23 ~ 131 °F)
- Operating humidity : 10 ~ 90 % RH (non-condensing)
- Construction : Plug-in
- Connection : M3.5 Screw terminals
- Housing material : flame-retardant Poly Carbonate (Black)
- Dimension : W52 x H77 x D112mm (2.04" x 3.03" x 4.40")
- Weight : about 320g

□ PERFORMANCE

- Accuracy : < ± 0.1 %
- Temp. coefficient : < ± 0.015 % /°C
- Response time : < 0.3 Sec. (0~90%, DC input) Filter set to the '0'
- Insulation resistance : 100 MΩ whit 500VDC
- Dielectric strength : AC 2000V / Min.
- Isolation : Input / Output 1 / Output 2 / Power
- Display range : 4 Digits (-1999 ~ 9999)

SCHEMATIC CIRCUIT & CONNECTION DIAGRAM

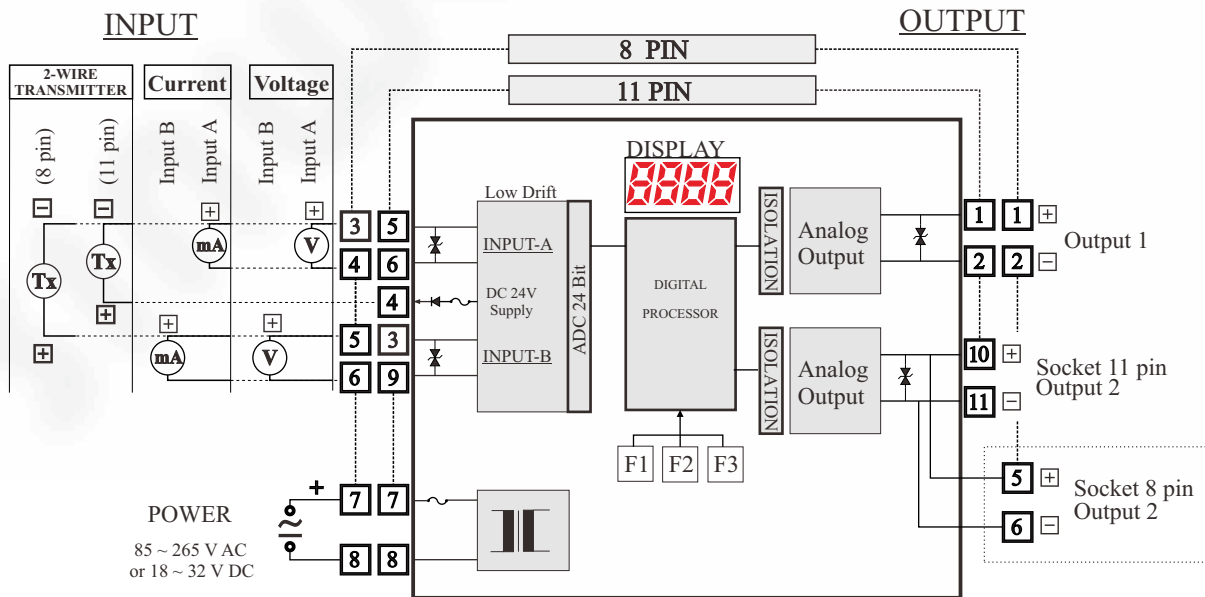

□ **Input & Output**

■ **INPUT (A & B) :**

● **CURRENT**

- Programmable range : -20 mA ~ +20 mA DC
- Measurement range : ±21 mA Max.
- Input resistance : 50Ω(0.5W)

● **LOOP POWERED CURRENT**

- Supply Voltage : 18 ~25 VDC(Terminal) / 4~20mA

● **VOLTAGE :**

- Programmable Range : -10V ~ +10V DC
- Measurement range : ±11 V DC
- Input resistance Normal : 1 MΩ

■ **ANALOG OUTPUT :**

- DC Current : 0(4)~20 mA DC max. (Load resistance : 600Ω max.)
- DC Voltage : -10V min. ~ +10V DC max. (Load Resistance : 10 KΩ or more)
- 2-Wire Transmitter(4~20mA DC), supply out voltage (9 V ~ 35 V DC)
- Easy Calibration of the Gain (Max. ±5% of F.S) and Offset(Max. ±5% of F.S).

■ **SERIAL INTERFACE**

- RS-485 / RS-232

■ **FUNCTIONS**

- Analog Calculations

- [000] Normal input (A)
- [001] Square Root (A)
- [002] Root Extraction (A)
- [007] ADDER(A+B) : Addition of 2 analog inputs
- [008] SUBTRACTOR(A-B) : Subtraction of 2 analog inputs
- [009] MULTIPLIER(A*B) : Multiplication of 2 analog inputs
- [010] DIVIDER(A/B) : Division of 2 analog inputs
- [011] HSS(AorB) High Signal Selection [LARGER]
- [012] LSS(AorB) Low Signal Selection [SMALLER]

- [101] Normal input (B)
- [102] Square Root (B)
- [103] Root Extraction (B)
- [108] SUBTRACTOR(B-A) : Subtraction of 2 analog inputs
- [109] DIVIDER(B/A) : Division of 2 analog inputs

- [201] Two Converters [input-A to Output-1, input-B to output-2]

- Peak-Hold

- [004] Peak-Hold(Higher)(A)
- [005] Peak-Hold(Lower)(A)
- [006] Peak-Hold(High/Low)(A)
- [105] Peak-Hold(Higher)(B)
- [106] Peak-Hold(Lower)(B)
- [107] Peak-Hold(High/Low)(B)

- Counter

- [003] INTEGRATOR (A) : Count of input range by count rate (Count Per Hour).
- [104] INTEGRATOR (B) : Count of input range by count rate (Count Per Hour).

- Communications

- MODBUS PROTOCOL (RTU) or other protocols
- ** Default set - Serial Port (1,2) **
- Baudrate : 19200 (set value "192")
- Data Bit : 8
- Start Bit : 1
- Stop Bit : 1
- Parity Bit : None

MODEL & SUFFIX CODE

NDSC- □ □ □ □ □ □ □

Input Type Selection (Available for Input A & Input B)

- 0 : None
- A : ± 20 mA DC (Impedance : 50 Ω / 0.5 W) [DC 0~1mA, 0~20mA, 4~20mA]
- B : 2-Wire Transmitter(4~20mA DC, Impedance : 50 Ω / 0.5 W) [supply out voltage (18 V ~ 25 V DC)]
- C : ± 10 V DC (Impedance : 1 MΩ min.) [DC 0~10V, -10~+10V]
- D : ± 5 V DC (Impedance : 1 MΩ min.) [DC 0~5V, 1~5V, -5~+5V]
- E : ± 1 V DC (Impedance : 1 MΩ min.) [DC 0~100mV, 0~1V, -1~+1V]
- F : ± 100mV DC (Impedance : 10 KΩ min.) [DC 0~10mV, 0~50mV, 0~100mV, -100~+100mV]

R : Other Special Spec.

Output Type & Range Selection (Available for Output 1 & Output 2)

- 0 : None
- 1 : DC 4~20mA (Load Resistance : 0~600 Ω)
- 2 : DC 0~20mA (Load Resistance : 0~600 Ω)
- 3 : DC 1~5V (Load Resistance : 5 KΩ or more)
- 4 : DC 0~5V (Load Resistance : 5 KΩ or more)
- 5 : DC 2~10V (Load Resistance : 10 KΩ or more)
- 6 : DC 0~10V (Load Resistance : 10 KΩ or more)
- 7 : DC -5~+5V (Load Resistance : 10 KΩ or more)
- 8 : DC -10~+10V (Load Resistance : 10 KΩ or more)
- 9 : 2-Wire Transmitter(4~20mA DC) (9V ~ 35V DC)
- A : Frequency output(Voltage)
- B : Frequency output(Open Collect(Drain))
- C : Serial Port RS-485
- D : Serial Port RS-232

R : Other Special Spec.

Power Supply

- Z : AC 85~265V
- Y : DC 18~32V

R : Other Special Spec.

Function

- 0 : Normal(Input-A) [Input-A to Output-1,2]
- 1 : Square root(A)
- 2 : Square Root Extractor(A)
- 3 : Adder (A + B)
- 4 : Subtractor (A - B)
- 5 : Multiplier (A * B)
- 6 : Divider (A / B)
- 8 : Two Independent transducers [Input-A to Output-1] and [Input-B to Output-2]
- A: HSS(High Signal Selection) / LSS(Low Signal Selection)
- S : Communication Protocol : Serial port(ONE or TWO)
MODBUS-RTU / SCOM / OTHER

R : Specify function

Socket

- A : 8 PIN
- B : 11 PIN

DEMENSION

